

DSTS-4A/3 OPERATORS MANUAL

Software V4.2XX



- 1.0 INTRODUCTION
- 2.0 INITIAL INSPECTION
- 3.0 GETTING STARTED
- 4.0 CONTROL FUNCTIONS
- 5.0 MENU STRUCTURE
- 6.0 ERROR MESSAGES
- 7.0 THEORY OF OPERATION
- 8.0 SPECIFICATIONS
- 9.0 IN CASE OF DIFFICULTY
- 10.0 OPTIONAL ACCESSORIES
- 11.0 WARRANTY
- 12.0 ADDENDUMS

Electronic Devices Inc. 3140 Bunch Walnuts Rd. Chesapeake, VA 23322

Phone 1-757-421-2968

Fax 1-757-421-0518

www.dsts.com

DS4_30P5WPD

1 INTRODUCTION

The DSTS-4A is a precision instrument designed for evaluation and repair of all types

of depth sounders. It is capable of measuring the incoming pulse parameters and generating a reply echo pulse over a very wide range of frequencies. For further information refer to the specifications. The micro-processor in the DSTS-4A controls all functions with the exception of the reply level. The incoming pulse is analyzed and displayed on the top line of the display. Outgoing parameters are displayed on the bottom line. Applying power to the DSTS-4A resets the processor and displays "WAITING FOR A PULSE." This message will remain on screen until the first pulse is received. Within three pulses the DSTS-4A begins to display and average the input information. The output frequency, depth, and pulse width are automatically set. To check the depth sounder under test (DUT), read the top line of the display to confirm the pulse parameters and adjust the reply level to measure the receiver sensitivity. Depth calibration can be done in feet, fathoms, or meters. The default velocity of propagation is 4800 feet/second in the foot and fathom range, and 1500 meters/second on the metric range. The values can be changed by the user.

2 INITIAL INSPECTION

Unpack the DSTS-4A. The shipping box will contain a wall plug power supply, manual, and any accessories you have ordered. Check the contents against the packing list and also check for mechanical damage. Please report any discrepancies to EDI as soon as possible. Save the shipping box should you need to return the unit.

2.1 PRELIMINARY ELECTRICAL TEST

Note: Do NOT connect a depth sounder to the DSTS-4A for this test.

The DSTS-4A comes with a wall plug transformer. This transformer is rated for 110-120 VAC 50-60 Hz current. If you have 220 VAC, use a 12 VAC, 500mA adaptor or order the optional 220 VAC transformer unit. Plug the transformer into the mains and connect the end of the cord to the power connector on the back panel of the DSTS.

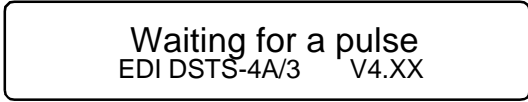

DSTS-4A Start-up display message

Turn the power switch on. The DSTS-4A will perform an oscillator calibration check and the startup message shown will appear on the liquid crystal display (LCD). This indicates the processor has passed the internal diagnostics. Depress and hold both the **FREQ** and **MODE** switches momentarily. The message should change to " Up/Dn *Auto Pulse Mode* ." The DSTS-4A will now put out a train of pulses at a frequency of 100 KHz. The frequency may be varied from 2.9 to 999.9 KHz using the **FREQ** switch. To restore the DSTS-4A to normal operation, momentarily raise the **MODE** switch. This completes the initial inspection and test of the DSTS.

3 GETTING STARTED

Reset the DSTS-4A by lifting the **MODE** switch momentarily. Set the **LOAD SELECTION** switch to **LOW**. Set the **REPLY LEVEL** switch to 50 mV. Connect a depth sounder directly to the **IN/OUT BNC** connector.

Note: Connecting a depth sounder with a balanced line (two wires and a shield), is easier if you use a balun. Refer to figure 1, showing the optional **BAL-550** balun.

CAUTION - never set the LOAD SELECTION switch to EXT LOAD without an external load plugged in. Some depth sounders can be damaged if connected to an open circuit.

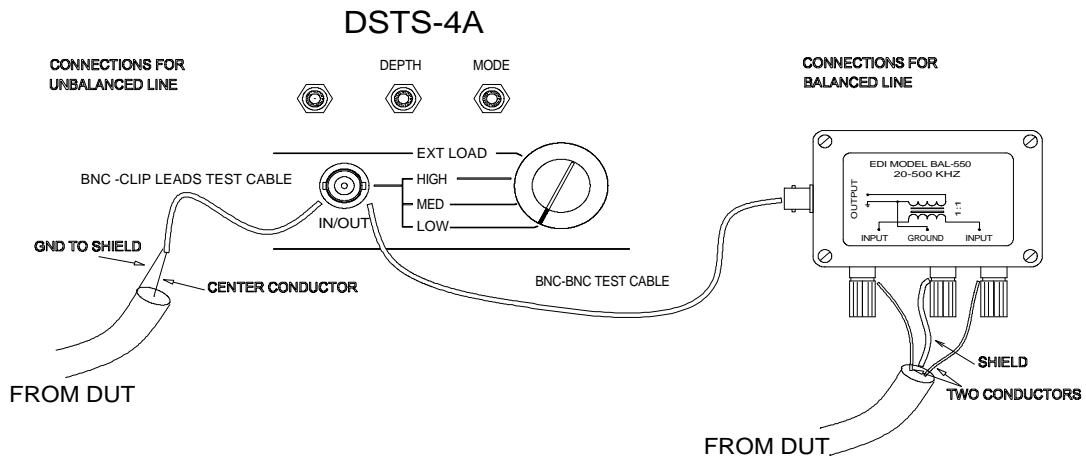
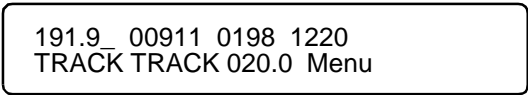

Fig 1

Apply power to the depth sounder. The PULSE LED will flash each time the depth sounder transmits, and the message "WAITING FOR A PULSE" will disappear. After receiving the third pulse, the top line will display the incoming frequency, width, period, and peak-to-peak voltage. The frequency and voltage are averaged and will stabilize after ten or more pulses have been received. The depth defaults to twenty feet when power is applied. The time that it takes for the readings to stabilize is based on the pulse repetition rate and pulse width of the DUT. Depth sounders that have high pulse repetition rates will produce a nearly instantaneous reading, while deep water sounders with pulse rates of one or less per second will take longer. Depress the MODE switch to select the calibration menu. From there, choose feet, meters or fathoms, Lifting the MODE switch will return you to the main display. Measure the receiver sensitivity by reducing the REPLY LEVEL to the point where the echo just disappears. This completes the most basic mode of testing.



DSTS-4A display with pulse input

4 CONTROL FUNCTIONS

Refer to figure 2 for control identification. The four switches below the display control the advanced operating features of the DSTS-4A. The first three grouped under the heading "REPLY" control the output frequency, width, and the reply depth. The fourth, or MODE switch is a multi- purpose switch. Lifting it returns the DSTS-4A to the normal

operating mode. Depressing it selects different menus, such as the CAL menu for setting the calibration units, i.e., feet, meters, or fathoms.

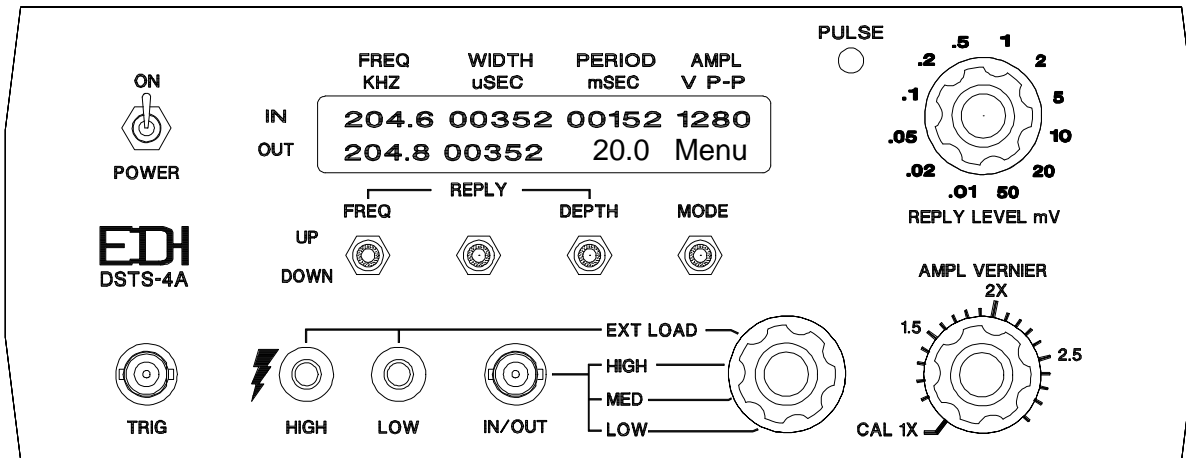

Fig 2

4.1 POWER SWITCH

The power switch turns the DSTS-4A on, resets the microprocessor, and restores all default modes and settings. For a normal reset, where the depth and other manual settings are retained, lift the mode switch. The power switch has no effect on the charge rate of the optional internal battery pack.

4.2 REPLY GROUP SWITCHES

Moving the FREQ or WIDTH switch will place the DSTS-4A in the manual mode for that function. This is indicated by replacing the word "TRACK" with the selected frequency or width. When the DSTS-4A is in the "TRACK" mode, the frequency and width track the input pulse parameters. This is the most commonly used mode. Some microprocessor-controlled depth sounders will have randomly varying pulse widths. When testing these units, the width must be in the "TRACK" mode so the echo width generated by the DSTS-4A will match the depth sounder's pulse width.

4.2.1 FREQUENCY SWITCH

The FREQ switch varies the reply frequency in .1 KHz steps. Lift it to increase the frequency, depress it to lower the frequency. The rate of frequency change will increase the longer the switch is held in position. The DSTS-4A operates in the manual frequency reply mode after the FREQ switch is moved. To restore the "TRACK" frequency mode of operation, momentarily lift then release both the FREQ and WIDTH switches. If the FREQ switch is released before the WIDTH switch is released, then only the frequency auto track mode is restored. This is useful if the value of a preset width is to be preserved.

4.2.2 WIDTH SWITCH

The WIDTH switch varies the reply width in 1 uSec steps. Lift it to increase the reply

width, depress it to lower the width. The rate that the width changes will increase the longer the switch is held in position. The DSTS-4A operates in the manual width reply mode after the WIDTH switch is moved. To restore the "TRACK" width mode of operation, lift then release both the FREQ and WIDTH switches at the same time. Some depth sounders deliberately vary pulse widths during operation to reject noise. When testing these units the WIDTH must be in the "TRACK" mode so the DSTS-4A's reply echo will follow the input pulse variations. If this is not done, the DUT may not respond.

4.2.3 DEPTH SWITCH

The DEPTH switch varies the reply echo depth. Lift it to decrease the depth, depress it to increase the depth.

4.2.4 SPEED SETTING FREQ, WIDTH, AND DEPTH

Example -- While holding the DEPTH switch down, press the MODE switch down for about ½ second and release it. The units digit will start changing. Press the MODE down twice more and the hundreds digit starts changing. This works with the frequency and width switches too. Each time the MODE switch is momentarily pushed down, the next digit to the left will begin changing. To set the least significant digit, momentarily release all switches and start again.

4.3 MODE SWITCH

Refer to the menu diagram in section 5 for further information. Lifting the MODE switch will display "----- Resetting -----" on the top line of the display and moves the menu up one level. Frequency, width, and depth settings remain as previously set, and the DSTS-4A frequency measuring gate will adjust for the best accuracy. Depressing the MODE switch will cycle down through the various menus. Refer to the MENU STRUCTURE in section 5 for further information on the mode and reply group switches.

4.4 REPLY LEVEL mV

The reply level switch varies the reply level from 10 microvolt (.01mV) to 50 millivolts RMS. The AMPL VERNIER must be rotated to the maximum counter clockwise position (CAL 1X) to obtain the output voltage selected.

4.5 AMPL VERNIER

The amplitude vernier multiplies the setting on the REPLY LEVEL switch. If the reply level is set to .2 mV and the AMPL VERNIER is set to 1.5, the actual reply level is .3 millivolts.

4.6 LOAD SELECTION SWITCH

The load selection switch selects from one of three internal load impedances or the external load jacks on the front panel. Refer to the partial schematic in figure 3.

4.6.1 LOAD SELECTION SWITCH - LOW

The low impedance position selects the lowest impedance internal load. This load is

330 Ω in parallel with 4700 pF. It is normally used with larger video and recording depth sounders.

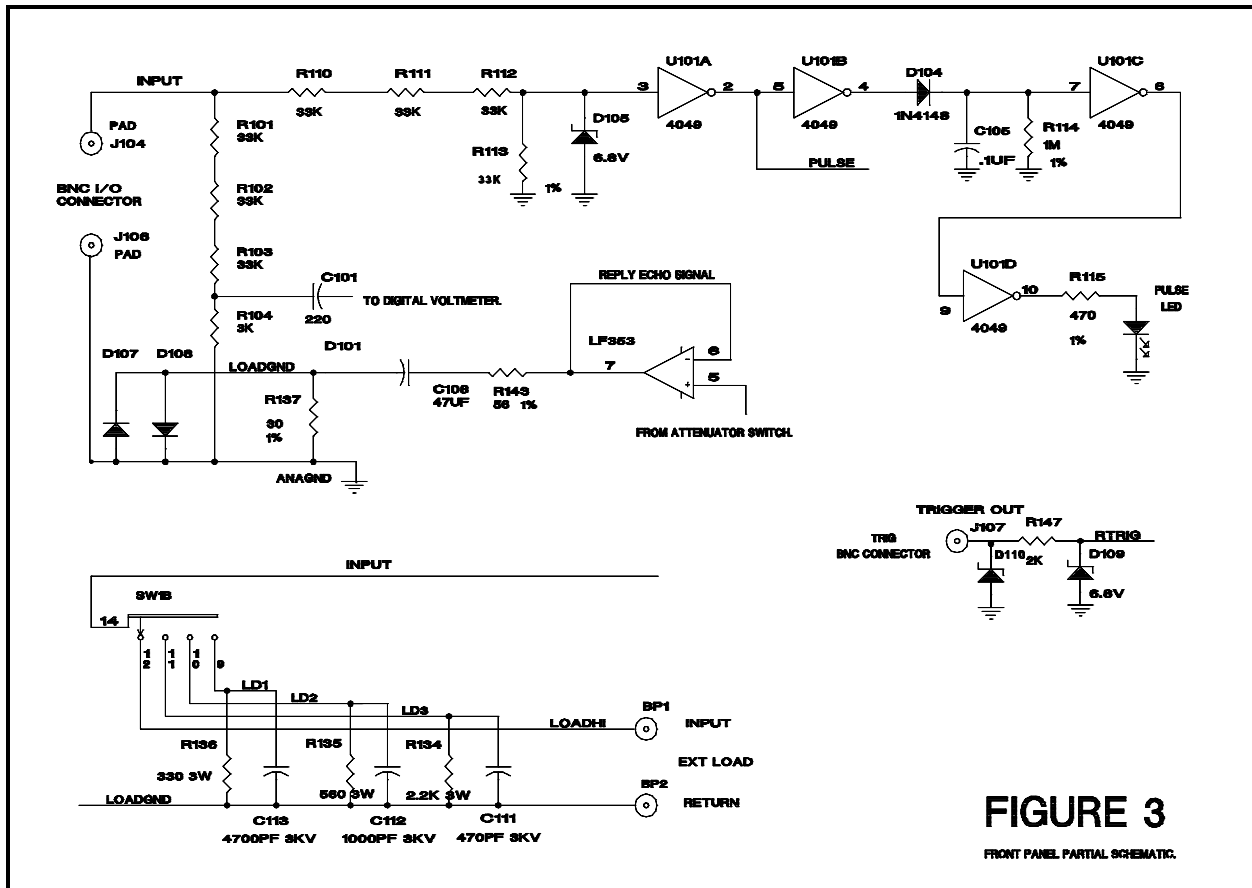

FIGURE 3
FRONT PANEL PARTIAL SCHEMATIC.

4.6.2 LOAD SELECTION SWITCH - MED

The medium impedance position selects the average or medium impedance internal load. This load is 560Ω in parallel with 1000 pF. It is used with most medium size depth sounders such as digital types with depth ranges up to 1000 feet.

4.6.3 LOAD SELECTION SWITCH - HIGH

The high impedance position selects the highest internal load impedance. This load is 2200Ω in parallel with 470 pF. It is used with small flashers and shallow water graphical depth sounders.

4.6.4 LOAD SELECTION SWITCH - EXT LOAD

The external load position selects the external load impedance connector jacks. Any external load can be constructed and connected across the red and blue banana jacks on the front panel. CAUTION, the red jack is the high voltage side of the load. The full pulse voltage appears at this jack. The blue jack is the low voltage return side of the load, and is not a ground. Do not ground the blue jack to the chassis or the reply pulse will be shorted to ground, and no reply echo will be seen. If no load is plugged into the jacks, the impedance at the IN/OUT BNC connector will be in excess of 50KΩ. This high impedance is nearly an open circuit and may damage high power depth sounders.

External loads are easily constructed using a double banana jack plug box similar to ITT/POMONA type 2098. Custom load boxes can be made to the depth sounder manufacturer's exact specifications and plugged in as needed.

4.7 IN/OUT BNC CONNECTOR

The DUT connects to this jack. For depth sounders with unbalanced (one wire and a shield) outputs, the connection is made directly to the DSTS. For depth sounders with balanced (two wires and a shield) outputs, use of a balanced-to-unbalanced load transformer such as the EDI model BAL-550 (shown in figure 1) is highly recommended.

4.8 TRIG BNC CONNECTOR

This connector provides a positive trigger output that precedes the reply pulse by 10 microseconds. It is used to trigger an oscilloscope so the reply pulse is easily tracked through the receiver sections of the DUT. **DO NOT CONNECT a depth sounder** to this connector. Doing so will harm the DSTS-4A. Usually the diode, D110, is destroyed. Reference figure 3 for further information.

5 MENU STRUCTURE OVERVIEW

The MODE key is used to select different menu screens. During the time the MODE switch is held down, a help screen will be displayed. It will provide information regarding the menu that will appear when the switch is released. When you have read the help screen, release the switch to go directly to the menu. The menu you have selected may redefine some of the keys. For example, the FREQ switch is redefined as FT in the CAL menu screen. To return to the Top Menu just lift the MODE switch one or more times. This returns the DSTS-4A to normal operation. Study the MENU DIAGRAM in section 5 and the operation will become clear.

5.1 MENU DIAGRAM DSTS-4A REVISION 4.XX SOFTWARE

A diagram of the new menu structure is included to help the user quickly select the various operating modes.

NOTE: The DSTS-4A must be receiving an input pulse from a depth sounder for these menus to appear.

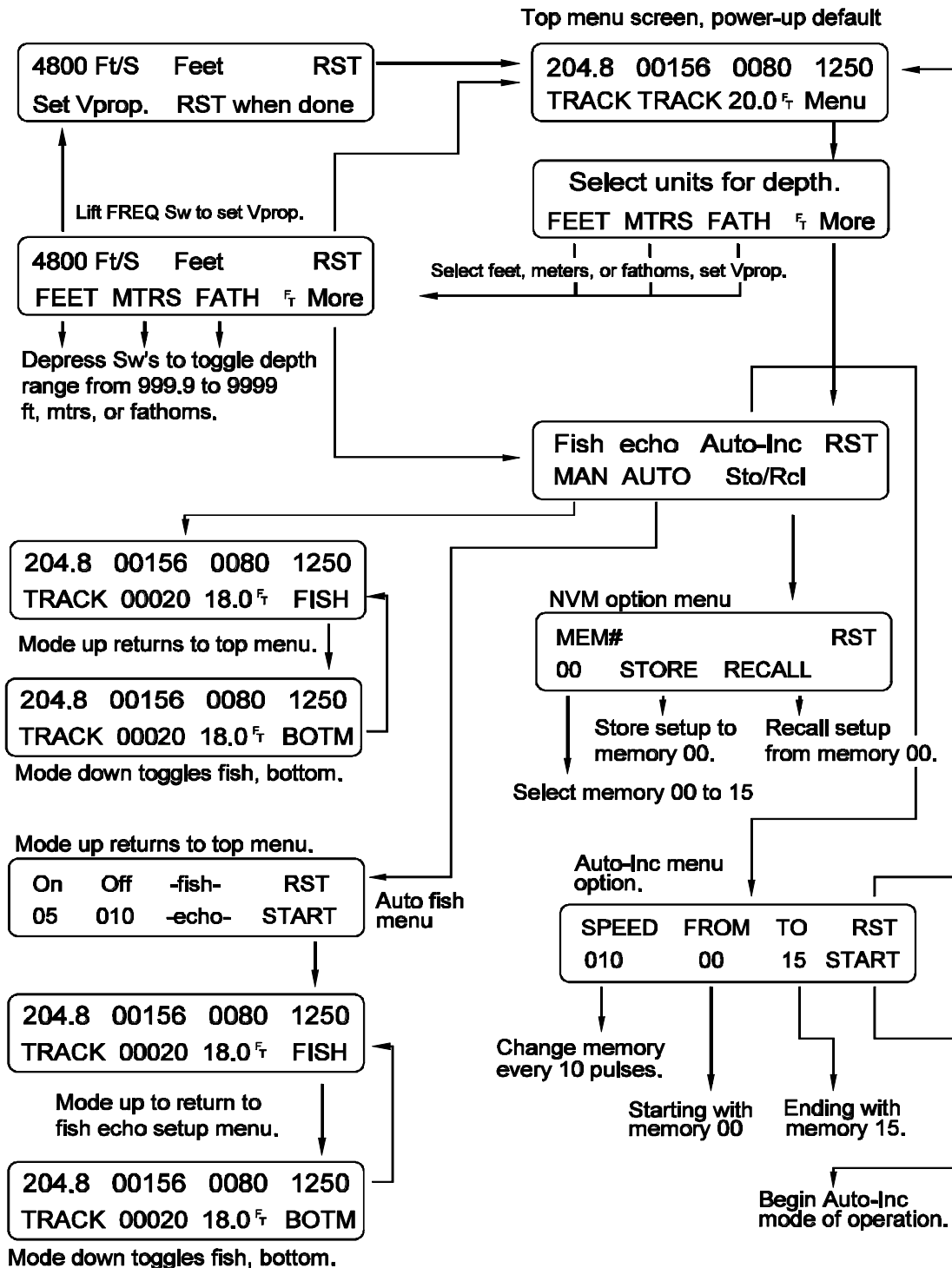

5.2 SELECTING UNITS OF CALIBRATION (feet, fathoms, meters)

From the top menu, push and hold the MODE switch. While the MODE switch is held down, a brief explanation of the upcoming menu is given. When the operator releases the switch, the actual menu appears. To select meters, briefly press down the switch under MTRS. The symbol for meters, M_T , will be displayed in the lower right area of the screen. To return to the top menu, just lift the mode switch. The DSTS-4A is now in the metric mode. This is indicated by the M_T symbol appearing just to the right of the depth readout. Note that depressing any switch consecutively changes the maximum depth range by a factor of 10. For example, repeatedly pressing the MTRS switch changes the reading at the top right of the display from "Meters" to "Mtr X 10".

5.2.1 SETTING THE VELOCITY OF PROPAGATION

The velocity of propagation may be independently set over the range of 4800 to 5000 feet/s for fathoms and feet, and 1460 to 1530 meters/s in the metric calibration mode. From the top menu, press the MODE switch down to enter the calibration menu. Select FEET, MTRS, or FATH. the current velocity of propagation will appear above the FREQ switch. At this point, momentarily lift the FREQ switch. The velocity of propagation is set by lifting or depressing the FREQ to increase or decrease the V_{prop} . The default values of 4800 feet/sec and 1500 meters/sec are restored whenever the DSTS-4A is powered up. Note that with the NVM (Non-Volatile Memory) option, settings for the velocity of propagation are retained indefinitely.

5.3 ENTERING THE MANUAL FISH MODE

From the top menu, depress the mode switch to enter the CAL menu screen, and then release it. Note that the MODE switch is labeled "MORE." Depress the switch to access the additional functions. The FREQ switch is now labeled as "MAN" to indicate that depressing it will enter the manual fish echo mode. Depress this switch and the fish menu screen will appear. Note the screen displays the new switch functions. The word "FISH" above the MODE switch indicates that the DSTS-4A is in the fish echo mode and is replying with two echoes. Set the fish echo width and depth from this menu screen. Cycling between the bottom (single echo) and fish (dual echo) mode is done by momentarily pressing the MODE switch down. When the DSTS-4A is in the bottom mode, as indicated by "BOTM" above the MODE switch, the bottom depth and width can be set. The bottom reply echo width tracks the pulse from the DUT unless the width has been manually set.

Note: The fish echo does **not** proportionally track the incoming pulse width, as the bottom echo does.

5.3.1 EXITING THE MANUAL FISH MENU

To exit the fish menu, lift the mode switch briefly and the top menu will appear. The previously entered values for fish depth and width are retained in memory until the power is turned off.

5.4 ENTERING THE AUTO FISH MODE

From the top menu, depress the mode switch to enter the CAL menu screen, and then release it. Note that the MODE switch is labeled 'MORE'. Depress the switch to access the additional functions. The WIDTH switch is now labeled as "AUTO" to indicate that depressing it will enter the auto fish echo mode. Depress this switch and the auto-fish menu screen will appear. The number of consecutive fish echoes returned is set using the FREQ switch. This can range from one to ninety-nine echoes. The off time for the fish echoes is set with the WIDTH switch. This can range from one to two hundred and fifty bottom echoes. The default values are for ten fish and bottom echoes followed by twenty bottom-only echoes. To start the Auto Fish generation, press the mode switch down. The Auto Fish menu will appear. Cycling between the bottom (single echo) and auto-fish (dual echo) mode is done by momentarily pressing the MODE switch down. To change the number of fish echoes, lift the mode switch once to go to the Auto Fish menu screen. Use the frequency and width switches to select the desired on and off times.



WAITING FOR A PULSE
EDI DSTS-4A V4.XX

DSTS-4A Start-up display message

5.4.1 EXITING THE AUTO FISH MODE

To exit the Auto Fish mode, lift the mode switch once to return to the Auto Fish menu. Lift it once more to return to the top menu. Fish and bottom depth and width are preserved along with the fish echo on-off times until the power is turned off.

5.5 ENTERING THE AUTO PULSE MODE

When the DSTS-4A is first turned on, the display will display the start-up message. The only way to enter the Auto Pulse mode is when this screen is displayed. This screen is only present **until** the DSTS-4A receives an input pulse. Therefore, the DUT should have its transmitter disabled or the power turned off to enter the Auto Pulse Mode. While this screen is displayed, depress and hold both the FREQ and MODE switches momentarily. The Auto Pulse Mode screen will appear, and the DSTS-4A will output a train of pulses at the selected frequency. If the WIDTH switch is lifted momentarily, the FACTORY TEST MODE screen will appear. The output will now be a continuous wave of the selected frequency. This is normally used to check the output level calibration. The output (no load) is nominally a 111 mV p-p square-wave with the reply level set to 50 mV and the LOAD switch to low.

5.5.1 PRODUCING A CONTINUOUS WAVE OUTPUT

While the start-up screen is displayed, depress and hold both the FREQ and MODE switches momentarily. The Auto Pulse Mode screen will appear, and the DSTS-4A will output a train of pulses at the selected frequency. If the WIDTH switch is lifted momentarily, the FACTORY TEST MODE screen will appear. The output will now be a continuous wave of the selected frequency. This is normally used to check the output level calibration with an oscilloscope.

NOTE: If you observe the output using a wide-band digital scope, the signal may appear noisy. This is due to the sampling nature of digital oscilloscopes. Use the

scopes waveform averaging function or a low-pass filter to reduce the noise.

5.5.2 EXITING THE AUTOPULSE OR CW MODE.

Momentarily lift the mode switch and the DSTS-4A will return to normal operation.

6 WARNINGS, ERROR MESSAGES, AND STATUS INDICATORS

If the DSTS-4A does not have the proper pulse input waveform, it could result in erroneous information being displayed on the screen. The software will detect these conditions and display an error message on the top line of the display. The process of acquiring and displaying the frequency of the DUT involves several steps. The current status is displayed to the right of the input frequency readout.

6.1 PULSE OVER-VOLTAGE WARNING

If this message appears on the display, **immediately** turn off the power to the DUT. Failure to do this could result in damage to the DSTS-4A and may not be covered



*** DANGER ***
PULSE VOLTAGE TOO HIGH

DSTS-4A over-voltage warning

under warranty. The input voltage should **never exceed** 2500 V p-p. Setting the load selection switch to LOW may reduce the voltage at the input because of the lower resistance presented to the DUT.

6.2 CYCLE ERROR WARNING MESSAGE

The message "cyc err" is displayed at the upper right of the display when the pulse contains less than four cycles. The width reading will be correct, but the frequency reading will not be, and "XXX.X" will flash in its place. Because of this, the DSTS-4A will immediately switch to the manual frequency mode. The message "TRACK" above the FREQ switch will be replaced by the frequency readings shown on the top line of the display if they were present before this error. The DSTS-4A must be operated in the manual frequency mode when insufficient cycles are present in the input pulse.

6.2.1 LOW CYCLE WARNING MESSAGE

The message "low cyc" will flash at the upper right of the display if six or less cycles are present, and indicates that the DSTS-4A is approaching the lower limits of its operational range. The DSTS-4A requires four more cycles to be present in the input pulse for normal operation. If possible, increase the number of cycles in the input pulse by adjusting the pulse length of the DUT.

6.2.2 BAD INPUT WARNING

The message "Bad In" will overlay the frequency display if the input pulse contains less than two cycles, is too narrow, contains a large DC component, or is otherwise not usable. Checking the input pulse with a scope while the DSTS-4A is connected will usually reveal the problem.

6.2.3 NARROW PULSE WARNINGS

If the input pulse is not wide enough for last-digit accuracy, the decimal point in the frequency readout will begin to flash. This indicates the accuracy has degraded to $\pm 0.05\%$ of the indicated reading. If the pulse is extremely short, the frequency display will show flashing question marks.

| | |
|------------------------|--|
| Decimal point flashes. | Accuracy within 300 Hz at 600 KHz, or $\pm 0.05\%$. |
| ???.? flashes. | Accuracy is worse than $\pm 1\%$. Use a longer pulse. |

6.1.4 OSCILLATOR SELF TEST

When the DSTS-4A is turned on, the oscillator frequency is checked by comparing the two on-board crystal-controlled frequency sources. The 50 KHz clock is measured and the results briefly displayed on the screen. If the oscillator is off frequency or inoperative, the following message will be displayed when the DSTS-4A is turned on: If the above message is displayed **DO NOT USE THE DSTS-4A** because the depth and frequency accuracy will not be within specification. The unit must be repaired and calibrated before it can be used. Please note that the DSTS-4A should be calibrated every two years regardless of the oscillator self-test results.

50KHz clock test failed.
Check oscillator freq.

6.3 FREQUENCY ACCURACY AND INPUT PULSE WIDTH

The DSTS-4A will work with pulses of 4 or more cycles and widths below 20 μs . For example, this makes the DSTS usable with a 35 μs input pulse at 200 KHz. To obtain good frequency accuracy with a 35 μs pulse, it is necessary to average many readings of the raw frequency data with a filter. For a very narrow pulse, the filter may average several hundred input pulses before settling at the correct value. This will take a lot of time if the input pulse repetition rate is slow. If the input pulse is wider, it contains more frequency information and the filter needs fewer pulses. Fewer pulses take less time and an accurate reading is displayed much faster. To compute an accurate frequency as rapidly as possible, the filter adapts to the width of the input pulse automatically. Since the time it takes to settle to the correct reading is variable, indicators of the filter's state are displayed in the space to the right of the 100 Hz input frequency digit.

6.3.1 FREQUENCY FILTER SETTLING TIME INDICATORS

| | |
|-----|---|
| "*" | Raw data is displayed. Filter is initializing and data may not be accurate. |
| " " | Filter is adapting to pulse width and frequency display becomes more accurate. |
| " " | Pulse width has decreased and filter time constant is readjusting. |
| "_" | Filter has settled. Frequency accuracy is within 100 Hz. |
| "_" | Filter has settled, but input pulse width is variable. Accuracy is within 100 Hz. |

6.3.2 TYPICAL ACCURACIES FOR NARROW PULSES

This table is a guide to the minimum practical combinations of frequency and pulse width required by the DSTS-4A with REV 4.XX software. It is not a specification for the accuracy of the DSTS-4A. In each case, the pulse width was reduced enough to blink the decimal point or display the "low cyc" error. Note that the lower frequencies must use a longer input width. The DSTS-4A requires at least six input cycles to work. Therefore, as the frequency drops, increasing pulse widths are required. In these cases (3.5 and 12.5 KHz) the width was reduced until the "low cyc" warning appeared.

| Input frequency (KHz) | Input width (us) | Measured frequency (KHz) |
|-----------------------|------------------|--------------------------|
| 3.5 | 2000 | 3.5 |
| 12.5 | 560 | 12.5 |
| 30 | 233 | 30.0 |
| 50 | 130 | 50.0 |
| 100 | 65 | 100.0 |
| 150 | 43 | 149.9 |
| 200 | 35 | 199.9 |
| 300 | 27 | 299.8 |
| 455 | 25 | 454.8 |

7 THEORY OF OPERATION

The DSTS-4A has a series of hardware counters that measure the incoming pulse characteristics. Based on the information contained in these counters, a microprocessor calculates the pulse parameters and displays them on the LCD screen. The first two and last two cycles of the input pulse are discarded as they adversely affect the accuracy of the frequency measurement. Notice the longer period of the cycles at the beginning and end of the waveform illustration to the right.

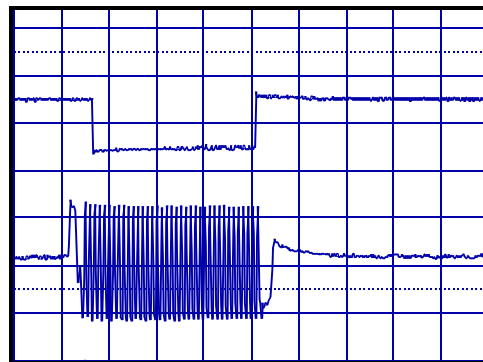

Tracking gate and input pulse

7.1 MEASUREMENT GATE

A measurement gate is generated that tracks the center area of the input pulse. The length of this gate is counted and the pulse frequency is calculated. If the pulse width varies on a pulse-to-pulse basis, the gate will try to adjust to the greatest possible width without extending beyond the limit of two cycles from the beginning and end of the pulse. Because the gate cannot predict what the width of the next input pulse might be, it tends to lock on to the narrowest pulse in the input stream. If the next pulse is longer, the gate will increase. This continues until a pulse that is shorter than the gate limits arrives. The gate then narrows and repeats the process. When the DSTS-4A is reset by the MODE switch, the gate is immediately forced to the maximum width for best frequency accuracy.

7.2 VOLTAGE MEASUREMENT

Voltage measurement is through a peak-to-peak detector and a ADC. The measurement is made about one millisecond after the end of the transmitted pulse. The indicated voltage will be the highest peak-to-peak value contained in the input pulse from the DUT.

7.3 WIDTH MEASUREMENT

A counter is activated when the first positive cycle of the pulse is encountered, and is stopped on the last negative cycle. The microprocessor reads the counter value and displays the width in microseconds. The accuracy of the width reading is one μs plus or minus the width of one cycle of the input waveform.

7.4 REPLY ECHO GENERATION

A time delay corresponding to the selected bottom depth is loaded into a hardware counter. This counter acts as a digital one-shot and is triggered by the first cycle of the input pulse from the DUT. When the counter times out, a reply echo is generated. If another input pulse arrives **before** the depth counter has timed out, the depth is reloaded and no echo is generated.

7.5 REPLY FREQUENCY GENERATION

A PLL circuit generates the reply frequency. Normally, this frequency is the same as the input frequency from the DUT.

7.6 REPLY ECHO WIDTH GENERATION

A hardware counter controls the echo duration. The counter is loaded with a width value that is approximately 1.3 times the width of the input pulse from the DUT. The increased width is necessary to simulate a realistic bottom echo. The bottom echo is wider than the transmitted pulse because some energy returns over a longer path due to the beam-width of the transducer.

7.7 INTERNAL LOAD IMPEDANCES

Refer to figure 3. The DUT connects to the internal load through the front panel IN/OUT connector. The low side of the load connects to the junction of D107, D108, and R137. This signal is referred to as LOADGND in figure 3. The reply signal from the attenuator buffer is applied to LOADGND through R143, and returns through the internal load to the IN/OUT connector.

7.7.1 EXTERNAL LOAD JACKS

Refer to figure 3. When the LOAD switch is in the EXT LOAD position, the external load jacks are selected in place of the internal loads. The red jack goes to J104, the input of the DSTS-4A. The blue jack goes to the LOADGND in the DSTS-4A. The external load goes between these two jacks. The reply signal on LOADGND is developed across R137, a 30 ohm resistor. The mechanical spacing of the banana jacks is three-quarters of an inch. This accepts standard dual-prong connectors.

7.8 REPLY TRIGGER BNC CONNECTOR

The reply trigger is a narrow (10 μ s) positive pulse that precedes start of the reply echo pulse by about 10 μ s. This trigger pulse is output to the BNC TRIG connector. It is normally used to trigger an oscilloscope when observing the return pulse in the receiver stages of a depth sounder. Please be careful not to do this. These components are located on the front panel just left and above the TRIG BNC connector. To gain access to these parts, the front panel must be disassembled, a procedure beyond the scope of this manual.

If a high voltage pulse is applied to the TRIG connector, D110 and possibly R147 will be destroyed.

8 SPECIFICATIONS for DSTS-4A/3 with software version V4.2xx and up.

WARNING!

| <u>Parameter</u> | <u>Range</u> | <u>Resolution</u> | <u>Accuracy</u> |
|---------------------|--|-------------------|-----------------------------------|
| Input frequency | 2.9 to 999.9 KHz | .1 KHz | $\pm 0.02\% \pm 100 \text{ Hz}^1$ |
| Input width | 20^2 to 20,000 μ s | 1 μ s | $\pm 0.02\% \pm 2 \text{ cycles}$ |
| Input period | 10 to 9999 ms | 1 ms | $\pm 0.02\% \pm 1 \text{ ms}$ |
| Input amplitude | 50 to 2500 Vp-p | 10 Vp-p | $\pm 5\% \pm 10 \text{ Vp-p}$ |
| Min input level | 30^3 Vp-p | N/A | $\pm 10 \text{ Vp-p}$ |
| Output frequency | 2.9 to 999.9 KHz | .1 KHz | $\pm 0.05\%$ |
| Output width | 10 to 20,000 μ s | 100 μ s | $\pm 0.02\%$ |
| Output depth | 1 to 999.9 ft/mt/fa | 0.1 unit | $\pm 0.02\%$ |
| Output Depth X 10 | 1 to 9999 ft/mt/fa | 1.0 unit | $\pm 0.02\%$ |
| Output level | 10 to 350,000 μ V | 1-2-5 steps | $\pm 1.5 \text{ dB}^4$ |
| Vprop ft, fm | 4800 to 5000 f/s | 1 unit | $\pm 0.02\%$ |
| Vprop mtrs | 1460 to 1530 m/s | 1 unit | $\pm 0.02\%$ |
| Power requirements: | 10-15 VAC or 12-18 VDC @ 120 mA nominal. | | |
| Size and Weight: | 10" W by 7"D by 4.5"H. Shipping Wt, 6 Lbs. | | |

9 IN CASE OF DIFFICULTY

This section discusses possible problems, their solutions, and how to open the DSTS-4A for service or curiosity.

9.1 FREQUENCY READOUT CHANGES VERY SLOWLY WHEN TUNING DUT

If the input pulse of the depth sounder under test is in the 20 to 40 μ s range, the time constant of the frequency filter will be very long. If the frequency of the depth sounder is changed, you must wait for the frequency display to "catch up" with the new input frequency. Because of this time lag, it is recommended that frequency tuning be done

¹ Specified for input pulse widths greater than 99 microseconds

² Input pulse must contain at least 6 cycles.

³ At 50 KHz. Approximately 200 Vp-p at 500 KHz.

⁴ At 500 KHz

with pulses over 100 μ s long. If this is not possible, tune the depth sounder a small amount, and wait for the reading to stabilize before making an additional adjustment. Always reset the DSTS-4A and wait for the filter to settle for maximum accuracy.

9.2 "???.?" APPEARS IN FREQUENCY READOUT

The depth sounder under test has too narrow a pulse output. Try setting the depth sounder to a deeper range. Most depth sounders will increase their pulse width on the deeper ranges. Reset the DSTS-4A to let it acquire the longer pulse.

9.3 DEPTH SOUNDER UNDER TEST WILL NOT ACQUIRE REPLY ECHO

If the DUT will not pick up the reply echo from the DSTS-4A, and you are sure that the DUT is a properly working unit, check the depth setting and the width mode. The depth must be set to a value less than the maximum depth range of the DUT. The width and frequency should be in the "TRACK" mode. Momentarily lift and release both the **FREQ** and **WIDTH** switches to restore the "TRACK" mode. Turning the DSTS-4A power switch off then back on will restore the default modes and depth settings.

9.3.1 IS THE DEPTH SETTING WITHIN RANGE?

The first thing to check is the depth setting. Make sure the DSTS-4A is set to a reply depth that is less than the range of the DUT. If the DUT is on the 15-foot range and the DSTS-4A replies at 20 feet, no echo will show as it is off range.

9.3.2 IS THE DSTS-4A IN THE AUTO WIDTH TRACK MODE?

Some depth sounders will not lock on to the echo if the DSTS-4A is not in the **AUTO PULSE** width tracking mode. Some sounders send a series of pulses with different widths and will reject the echo from the DSTS-4A if it is set to a fixed width. Lift and release the **FREQ** and **WIDTH** switches to put the DSTS-4A in the width tracking mode. Increase the **REPLY LEVEL** to the maximum. After the sounder locks on to the echo, reduce the **REPLY LEVEL**. You may have to repeat the above steps if the depth is quickly changed by a large amount.

9.4 INCONSISTENT FREQUENCY READINGS

Certain conditions will cause inconsistent or incorrect frequency readings.

- 9.4.1 If you are measuring a dual-frequency depth sounder, be sure to set it for single frequency operation.
- 9.4.2 Try using a longer input pulse width. This can usually be done by increasing the depth range of the DUT (Device Under Test), or by rotating "suppression" or "discrimination" controls on the DUT.
- 9.4.3 Change the DSTS-4A load switch to a different impedance range. Lowering the load impedance will drop the "Q" of the tank circuit and the effect of the pulse ringing or chirp on the frequency reading will be minimized.
- 9.4.4 Check the input waveform to the DSTS-4A using an oscilloscope. Look for stray high voltage spikes or DC voltage offsets exceeding ± 20 VDC.

NOTE: Always turn the DUT off when changing the load impedance.

9.4.5 FREQUENCY CHANGES WITH LOAD IMPEDANCE

If the frequency changes several percent with a change in load, the DUT's oscillator is experiencing "load pulling". This is usually not critical, and often occurs with inexpensive sounders. However, if the same DUT is checked with two different DSTS-4A's, the frequency readings may vary slightly. This is due to the tolerance of the capacitive portion of the internal loads of the DSTS-4A. This is not an error in the DSTS-4A, but merely reflects the fact that the DUT oscillator is sensitive to external load variations.

9.5 HOW TO GET THE MOST ACCURATE FREQUENCY READING.

The accuracy of the frequency reading depends on several factors. The single most important one is the width of the pulse. When a pulse burst is generated and sent through a bandpass filter, the period between the zero crossing points of the first and last few cycles is different than the period between the zero crossing points in the center of the pulse. Additionally, this problem is aggravated if the pulse has some "chirp" or frequency change with time. Chirp is usually encountered with keyed oscillators found in inexpensive depth sounders, and can cause a significant frequency change in the first portion of the pulse. For this reason, the DSTS-4A discards the first and last few cycles of the pulse from the DUT. As the pulse width gets narrow, the DSTS-4A has fewer cycles in the center of the pulse with accurate zero crossings to calculate the frequency width. Therefore, contamination of the first two or more cycles has a greater effect on the frequency reading of short pulses. Accurate readings are obtained by using the longest possible pulse. Always reset the DSTS-4A **after** the input pulse has been increased. The reset forces the DSTS-4A to search the pulse pattern for the longest usable gate width, thus yielding the greatest accuracy.

9.6 OPENING THE DSTS-4A

Any time you open the DSTS-4A, you should be working on a static mat. The integrated circuits used in the DSTS-4A are very sensitive to static discharge. Please exercise all due caution. Unplug the power cord from the DSTS-4A and remove the four rubber stick-on feet by peeling them off with your fingers. Remove the four screws recessed in the plastic feet and remove the feet and plastic bail. Set the DSTS-4A upright and carefully lift off the top half of the case, including the black band. Make sure that the back panel **DOES NOT** lift up as you do this. If the back panel lifts, the voltage regulator may be torn from the main board. The front panel should also stay with the bottom part of the case.

9.6.1 REPLACING THE EPROM

Remove U21, the EPROM that is located on the main board near the left front corner. Replace this with the new EPROM. Make sure that pin one is towards the notch in the socket and that all the pins are properly inserted into the socket.

9.6.2 CLOSING THE DSTS-4A

Dress the ribbon cables **away** from the front panel. This is very important because some of the front panel PCB traces carry the full input pulse voltage. This voltage may be up to 2,500 volts. If an arc occurs from the PCB to the ribbon cable, the main PCB

will be severely damaged. Place the cover on with the ventilation slots near the back panel. Slide it in place and replace the plastic feet, tilt bail, screws, and rubber feet. Do not over tighten the case screws. Replace the rubber feet.

9.7 GETTING TECHNICAL SUPPORT

If you have questions not covered here, or require more information, please call, fax, or e-mail us. You may reach technical support at the following numbers:

Phone 1-757-421-2968 Fax 1-757-421-0518 www.dsts.com

10 OPTIONAL ACCESSORIES

This section lists options available for the DSTS-4A.

10.1 BAL-550 MATCHING BALUN

The BAL-550 is a balanced-to-unbalanced line transformer. It should be used when connecting a depth sounder having two wires and a shield to the DSTS. Binding posts for the shield and two signal conductors make connections easier. External noise rejection is improved, and receiver sensitivity measurements are more accurate.

10.2 BP-4A INTERNAL RECHARGEABLE BATTERY PACK

A rechargeable internal battery gives over 4 hours of continuous field operation from the DSTS-4A. Recharging is automatic and occurs whenever the DSTS-4A is connected to a source of external power.

10.3 RS-232 OPTIONS

There are two RS-232 options available. The basic RS-232 option allows remote setting of all parameters except amplitude, and the EAB-3 option allows complete control of all functions including reply amplitude.

10.4 NVM OPTION

The NVM (Non-Volatile Memory) option retains up to 16 complete setups. Depth, calibration (feet, meters, or fathoms), width, frequency and velocity of propagation can be recalled and sequenced automatically.

10.5 DSTS-4A SERVICE MANUAL FOR HARDWARE REVISION 3

The service manual covers the repair, calibration and theory of the DSTS-4A. Full schematics, waveform illustrations, and parts lists are included in this manual.

11 WARRANTY INFORMATION

Unit will be repaired free of charge for one year from date of purchase providing there is no water damage or other evidence of improper use or handling. Purchaser must ship unit prepaid to address below; EDI will pay the return freight.

For repair ship to:

Electronic Devices, Inc.
3140 Bunch Walnuts Road
Chesapeake, VA. 23322
ATTN: Service Department

Please enclose a note describing the problem.

12 ADDENDUMS

New features and capabilities are constantly pursued to keep the DSTS-4A current with emerging depth sounder technology. As software updates are issued, addendums will be sent along with the EPROM. These should be inserted following this page to keep this manual up to date. You may also check our web site, www.dsts.com, for latest information on our products, updates, and accessories.